

PRZEKRÓJ E-E

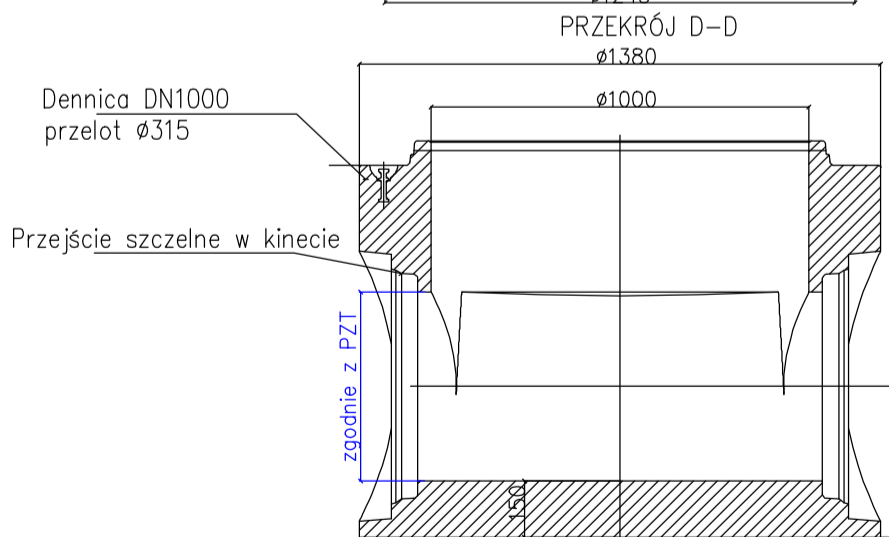
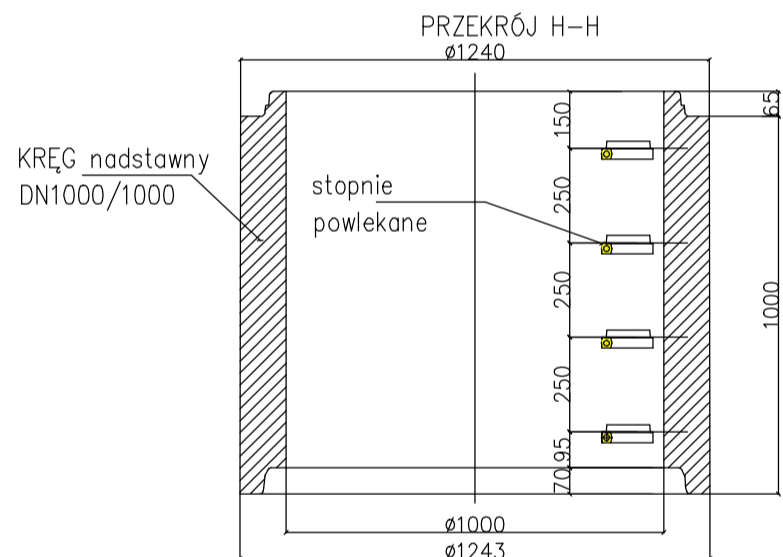
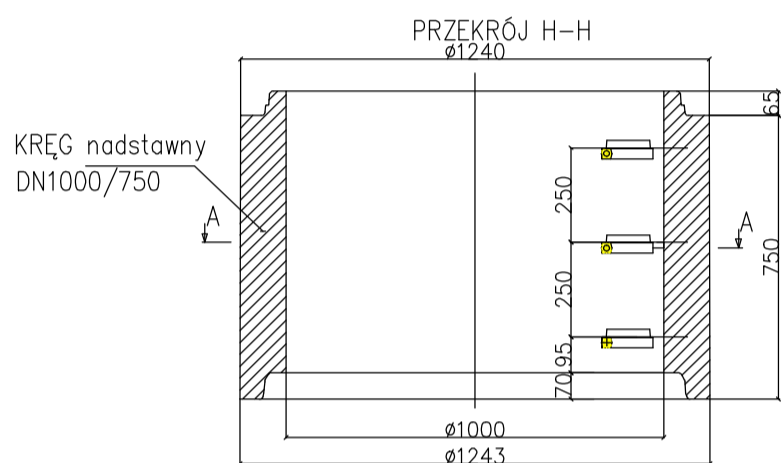
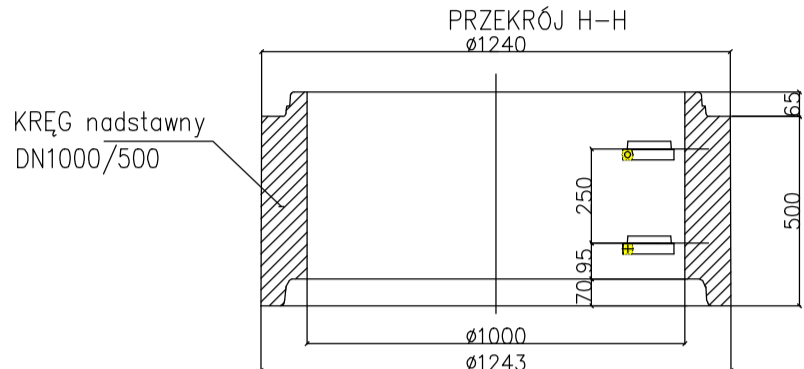
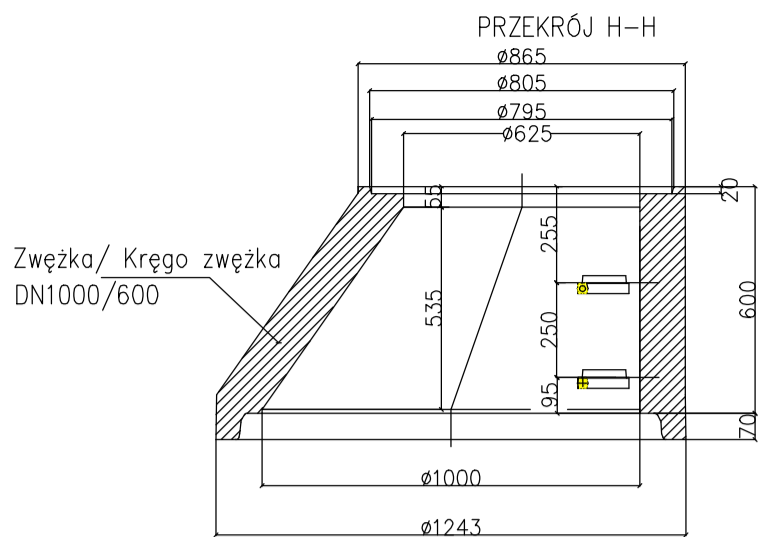
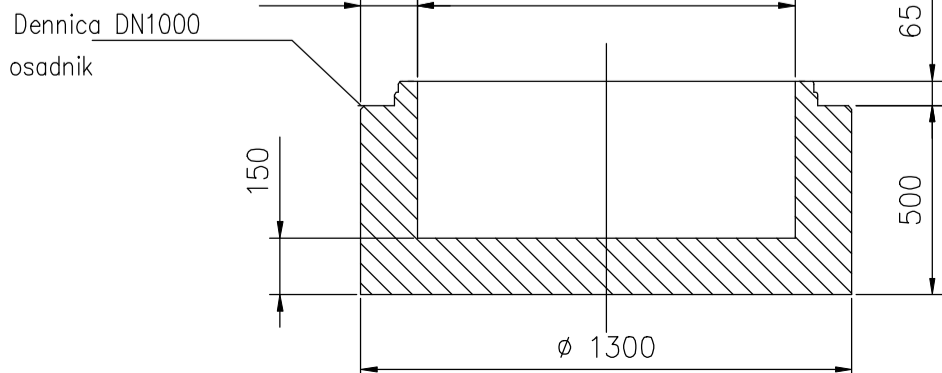
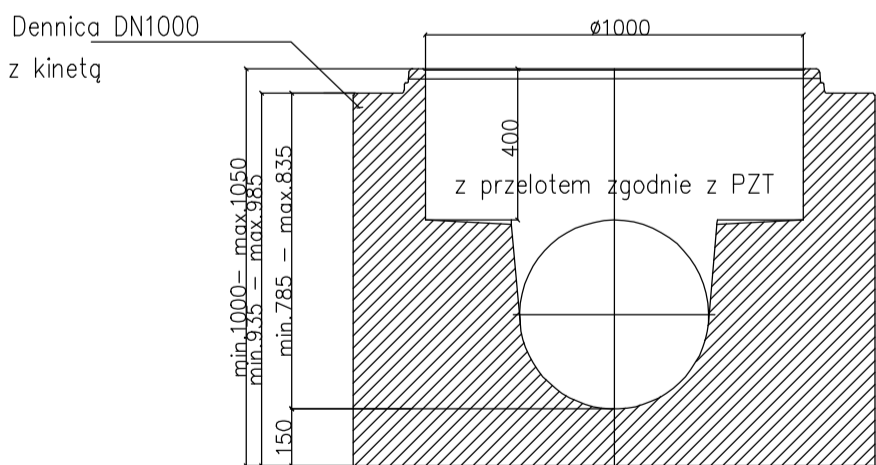

UWAGA

Dla przejść sieci oraz dla przykanalików zastosować przejścia szczelne

SZCZEGÓŁ- STDNIA BETONOWA FI 1000

PRZEBUDOWA DROGI POWIATOWEJ NR 1056F
w km od 4+540,00 do 5+386,00

INWESTOR	POWIAT ŻAGAŃSKI UL. DWORCOWA 39 , 68-100 ŻAGAŃ	NUMER RYSUNKU
PROJEKTANT	mgr inż. Daniel Sadowski	
SKALA RYSUNKU	1 : 20	4.1
DATA OPRACOWANIA	MAJ 2017	